



# HANOVER TOWNSHIP FIRE DEPARTMENT HANOVER TOWNSHIP, PA

SO.141004 / QUOTE 70582

CUSTOM 36 PUMPER

E-ONE TYPOONI X LONG CAB 4X2 CHASSIS

1750 GPM HALE QMAX PUMP 750 GALLON WATER TANK 30 GALLON INTEGRAL "B" FOAM CELL	HOSE LOAD:			
	200' OF 3.00" DJ			
	200' OF 2.50" DJ			
	1200' OF 5.00" DJ			
	400' OF 1.75" DJ			
400' OF 2.50" DJ				

COMPT.	OPENING	INTERIOR DIMENSION			
L1/L3	34W 59H	36W 36W	25H 30H	12D 26D	UPPER LOWER
L2	54W 25H	56W	25H	12D	
R1/R2	34W 21H	36W	25H	26D	
B1	34W 34H	38W 38W	6H 30H	4D 26D	UPPER LOWER

THIS DRAWING IS FOR REFERENCE PURPOSES. ALL DIMENSIONS ARE  
SUBJECT TO MINOR VARIATIONS DUE TO MANUFACTURING PROCESSES.

APPROVED FOR PRODUCTION

DESIGNER: \_\_\_\_\_

DATE: \_\_\_\_\_

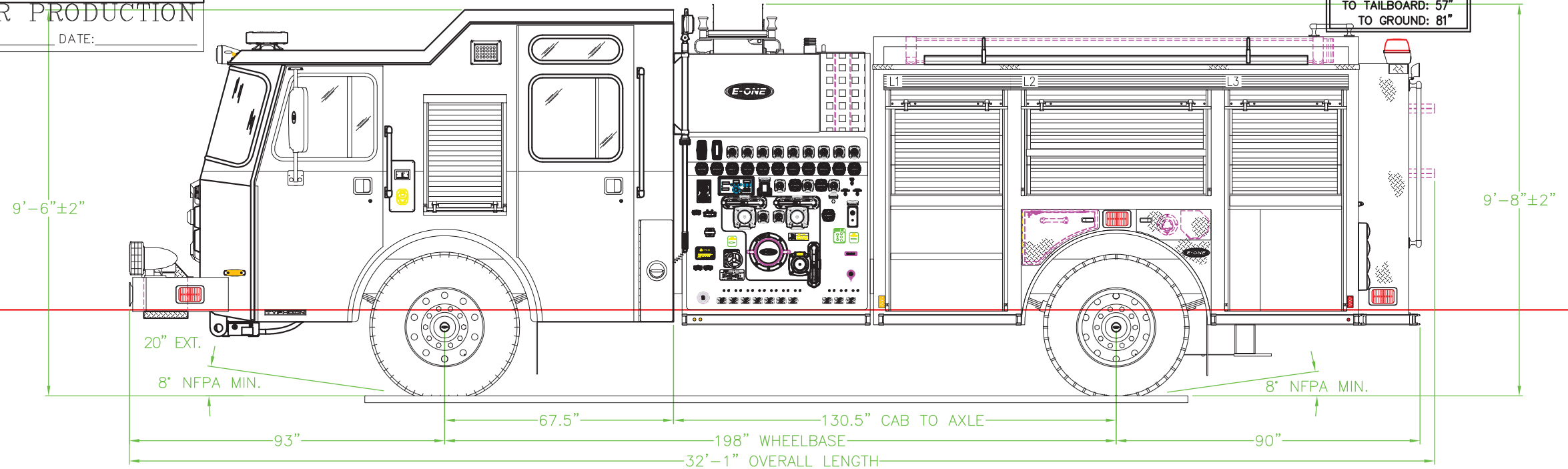
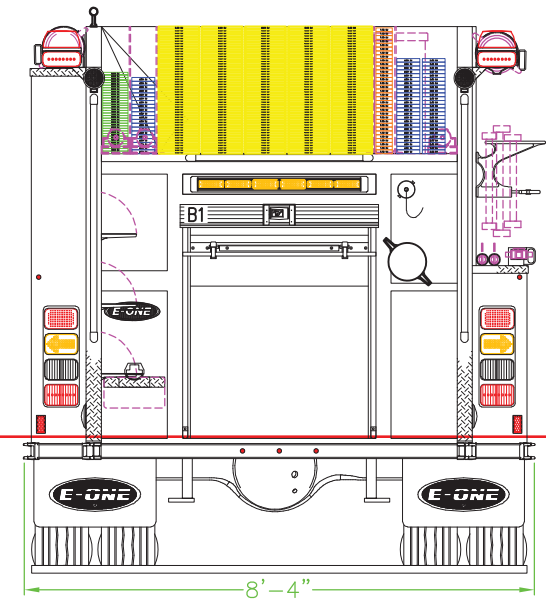

HOSEBED HEIGHT:  
(FOR REFERENCE ONLY)  
TO TAILBOARD: 57"  
TO GROUND: 81"

DESIGNER	REV	DESCRIPTION	DATE	APPROVED
JAMMOND	C	REV C	2017-04-25	JAMMOND
JAMMOND	B	REV B	2017-04-19	JAMMOND
DALLASER	A	INITIAL RELEASE	2017-02-14	DALLASER
DRAWN BY	REV	DESCRIPTION	DATE	APPROVED
APPROVAL REVISIONS				



**HANOVER TOWNSHIP FIRE DEPARTMENT**  
**HANOVER TOWNSHIP, PA**  
*SO.141004 / QUOTE 70582*  
**CUSTOM 36 PUMPER**  
**E-ONE TYPOONI X LONG CAB 4X2 CHASSIS**

THIS DRAWING IS FOR REFERENCE PURPOSES. ALL DIMENSIONS ARE  
 SUBJECT TO MINOR VARIATIONS DUE TO MANUFACTURING PROCESSES.

**APPROVED FOR PRODUCTION**

DESIGNER: \_\_\_\_\_ DATE: \_\_\_\_\_

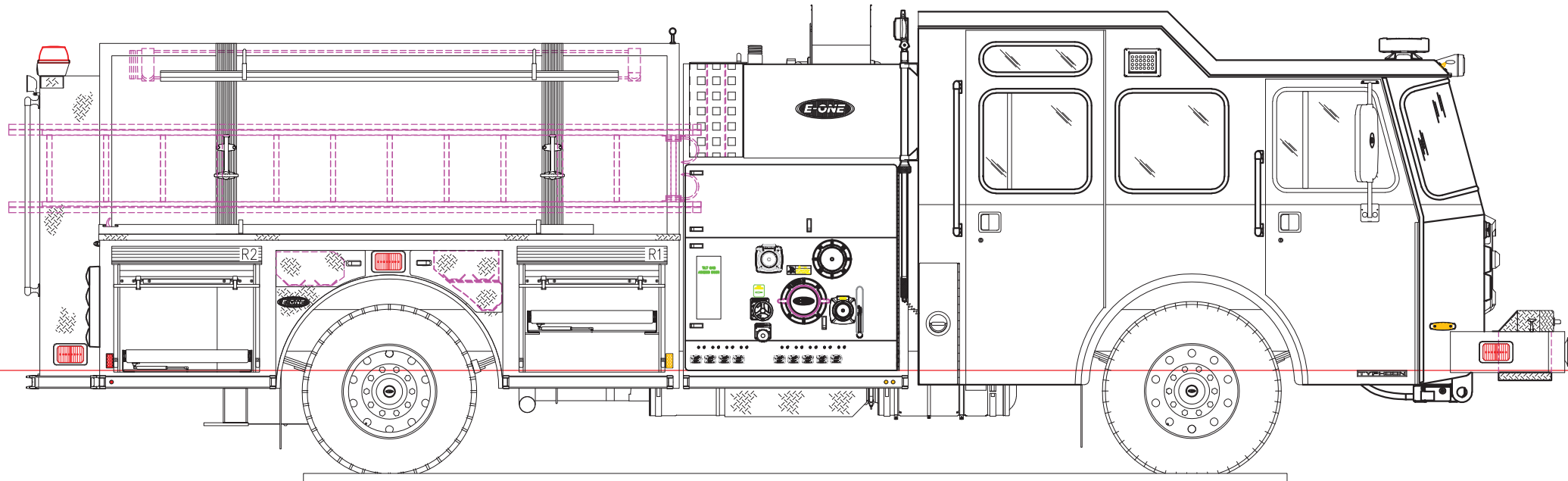
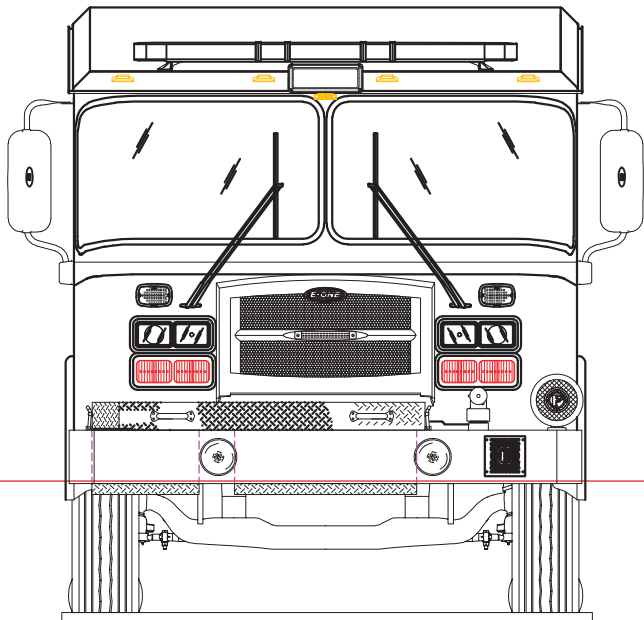

APPROVED	REV	DESCRIPTION	DATE	APPROVED
JHAMMOND	C	REV C	2017-JUN-23	JHAMMOND
JHAMMOND	B	REV B	2017-JUN-19	JHAMMOND
DALLAGHER	A	INITIAL RELEASE	2016-NOV-16	DALLAGHER
DRAWN BY	REV	DESCRIPTION	DATE	APPROVED
		APPROVAL REVISIONS		SHEET 2 OF 2